

Product Manual

CREALITY
FALCON

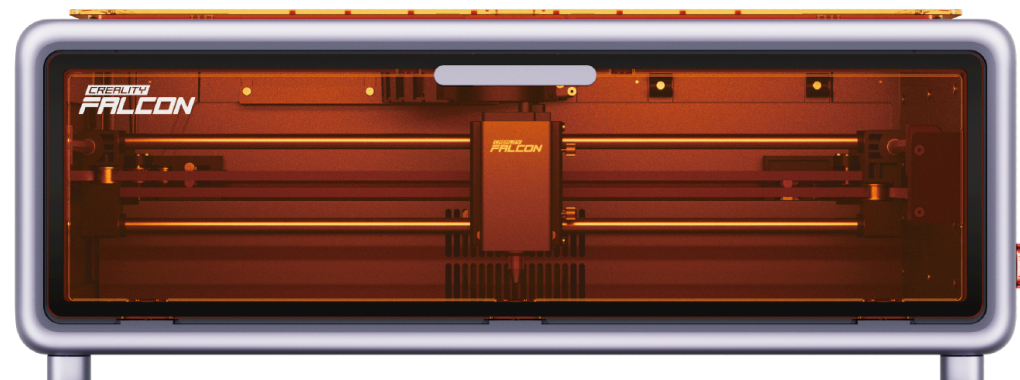

Creality Falcon A1

Product Manual V1.1

Don't Miss Out! Access Free Files & Join the Official Falcon Laser Community!



Download FREE Laser Files on CraftSeek! What's waiting for you on craftseek.com?

- Access exclusive, free laser files ready to download and create with!
- Download Falcon Design Space software for free and start designing!

Featured items

See More →

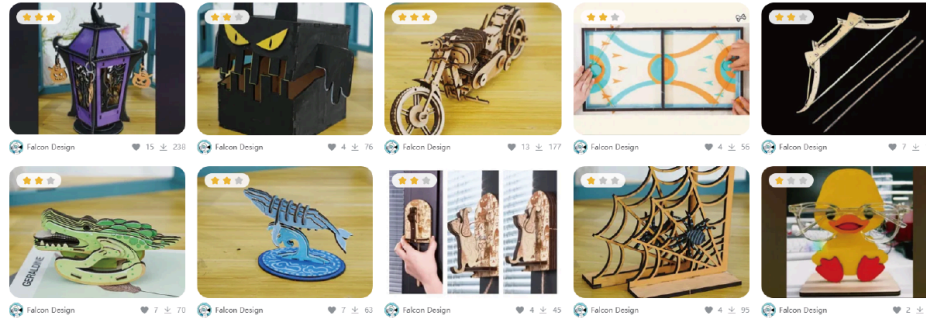

Join the Official Falcon Laser Engraver User Group! Why be part of the official community?

- Connect with authentic Falcon users to learn, share, and inspire
- Get expert support and tips from experienced members
- Build connections with Falcon laser crafters worldwide

Operation Guide

Installing Software

Download and install the engraving software (Falcon Design Space / LightBurn). The machine's camera has been automatically calibrated at the factory, so no further calibration is needed. If there is a significant camera positioning deviation, it is recommended to recalibrate. Specific files can be found in the "Camera Calibration Guide" under the teaching files at wiki.creality.com/en/laser-engraver.

Creating Engraving Images

Find the image you want to engrave. The higher the resolution, the clearer the result.

Setting Parameters

Set the engraving parameters. You can refer to the "Parameter Recommendation Table" in the file link at wiki.creality.com/en/laser-engraver. For specific operations, follow the prompts in the engraving software or check the software tutorial file "Software User Guide" at wiki.creality.com/en/laser-engraver.

Start Engraving

Activate the start button and wait for your new creation to appear.

Product Assembly

Directly refer to the product installation steps in the manual for product assembly, or visit wiki.creality.com/en/laser-engraver to view the "Assembly Guide Video" for the product.

Adjusting Focus

Place the engraving material and use the multi-level focusing bar to focus. Connect the computer and device to begin our journey.

G-Code Projects

You can download the corresponding product's "G-code" file from wiki.creality.com/en/laser-engraver to engrave your first project and check the structural stability of the device.

Place the "G-code" file for the corresponding power in the root directory of a (self-provided) USB drive, and use a USB-A to USB-C adapter to connect the USB drive to the machine's port.

Connect the (self-provided) USB drive to the machine using the USB-A to USB-C adapter, then press the Start button once to adjust the position of the engraving material.

Press the Start button again to start the machine and create your project.



Thank you letter!

Dear user,

Thank you for choosing Creality Falcon's product. On this journey, we look forward to you creating works of unlimited possibilities. You can follow Falcon Laser on social media platforms such as Facebook, TikTok, and Instagram, where you can share your works and gain inspiration from others.

The Creality Falcon team is always ready to provide you with quality service. If you encounter any problems during use, please contact us using the phone number and email provided in the product manual. To better experience our products, you can obtain relevant instructions and videos from Wikipedia (wiki.creality.com/en/laser-engraver). Or visit the official Creality Falcon store (www.crealityfalcon.com) to find information on related hardware and software, contact methods, equipment operation, equipment maintenance, etc.

Contents

EN

Operation Guide

Thank You Letter

01 Safety Instructions - - - - - 06

02 Packing List - - - - - 07

03 Assembly Steps - - - - - 09

04 Product Structure - - - - - 13

05 Product Specifications - - - - - 14

06 Laser Module - - - - - 14

07 Instructions for Use - - - - - 15

08 Maintenance - - - - - 17

09 Troubleshooting - - - - - 19

I. Safety Instructions

The laser engraver uses a high-density laser beam to irradiate materials for engraving or cutting, generating high temperatures on the material surface to vaporize it without burning. However, most materials are inherently flammable and may ignite, forming open flames that could damage the machine and surrounding environment.

 Please follow these operating principles:

1. Do not place this product near flammable or explosive items, volatile solvents, or high heat sources. Place it in a well-ventilated, cool, and low-dust environment.
2. Do not use power cords from other products during installation. Use the power cord provided with this product.
3. Regularly clean the machine body and laser module with an anti-static brush and dry cloth when powered off.
4. Always connect the silicone tube to the laser module, whether using air assist or not, to prevent lens contamination.
5. The laser operating environment temperature is 5°C-35°C. Avoid using this product in humid environments and never use it during thunderstorms.
6. If not using the product for an extended period, turn it off and unplug the power cord.
7. Do not touch electronic-related areas with hands or tools when the product is connected to power. Never plug or unplug the laser module cable while powered on.
8. Do not touch moving mechanical parts or the laser module while the product is running.
9. Always place a laser-impenetrable flat object, such as aluminum alloy, under the processing material.
10. Always wear protective goggles during laser engraving to avoid eye damage from direct laser beam exposure.
11. Laser engraving and cutting may produce slight smoke or odors. It is recommended to operate in a well-ventilated environment.
12. Children under 10 years old are strictly prohibited from using this product without adult supervision to prevent personal injury.
13. Prepare a fire extinguisher for backup and maintain and inspect it regularly.
14. Strict supervision is required during machine operation.
15. Users should comply with the laws and regulations of the country or region where the equipment is located (used), adhere to professional ethics, pay attention to safety obligations, and strictly prohibit the use of our products or equipment for any illegal purposes. We are not responsible for any legal liabilities in case of violations.



Use of controls or adjustments or performance of procedures other than those specified herein may result in hazardous radiation exposure. The laser safety classification of this product follows the IEC60825-1:2014 standard, with the safety class of laser radiation emitted through the laser aperture exceeding Class 1.

II. Packing List



The Principal Part



Exhaust Pipe



Hose Clamp



Air Assist Equipment



Silicone Tube



Power Supply



Basswood (300*300*3mm)
Materials QR Code Card



Test Calibration Card



Rotary Kit
Connection Cable

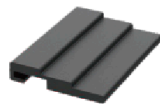

Multi-level Fixed
Focus Block



Type A to
Type C Cable



Anti-static Brush



Allen Wrench



User Manual

Assembly Tool Kit



M1.5/M2/M2.5/M3
Allen Wrench



Tweezers



Dust-free Cloth



Protective Len



Type A to
Type C Adapter



Safety Keys*2

Optional



Smoke Purifier

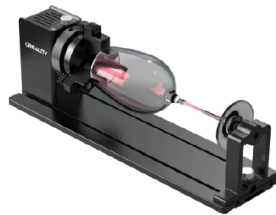

Rotary Kit



Risers

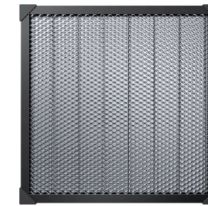

Honeycomb Board



Safety Goggles

III. Assembly Steps

1. Pull out the air pump nozzle, connect the silicone tube to the air pump

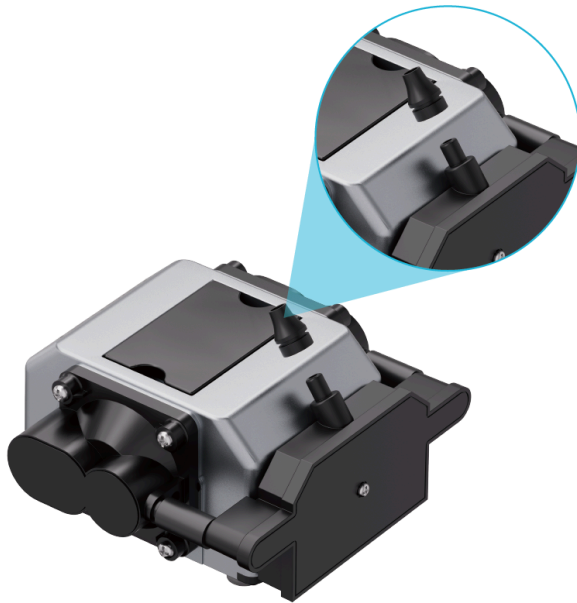

Need help?
Scan the QR code to watch the installation video.

2. Connect the air assist device, install the silicone tube



3. Install the exhaust pipe with the clamp on the machine's exhaust port

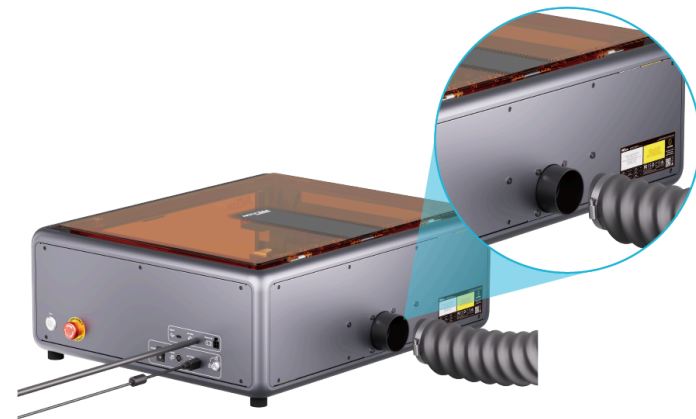

4. Use the hex wrench to tighten the clamp

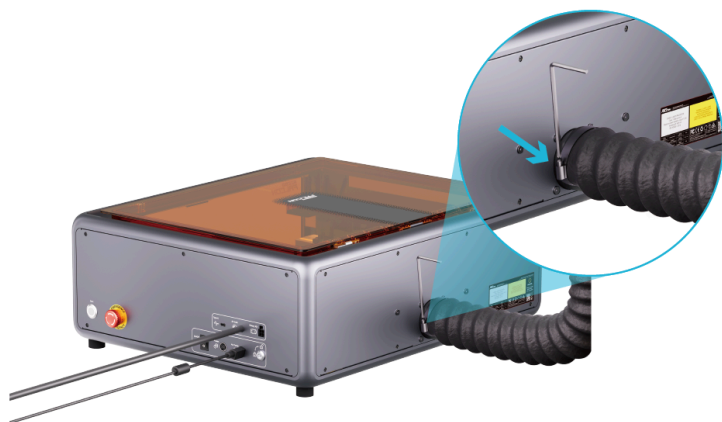

5. Connect the adapter power cord

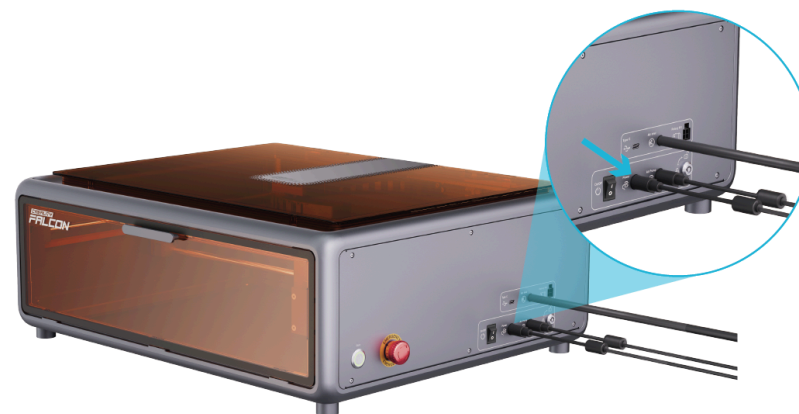

Need help?
Scan the QR code to watch the installation video.

6. Insert the safety key and turn it on

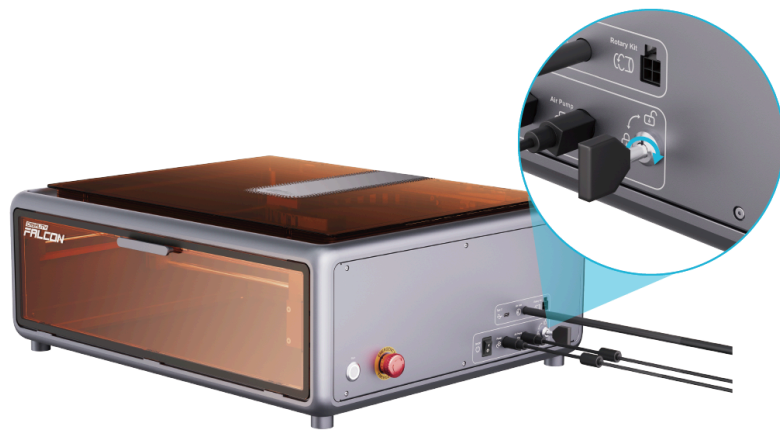

7. Turn on the rocker switch

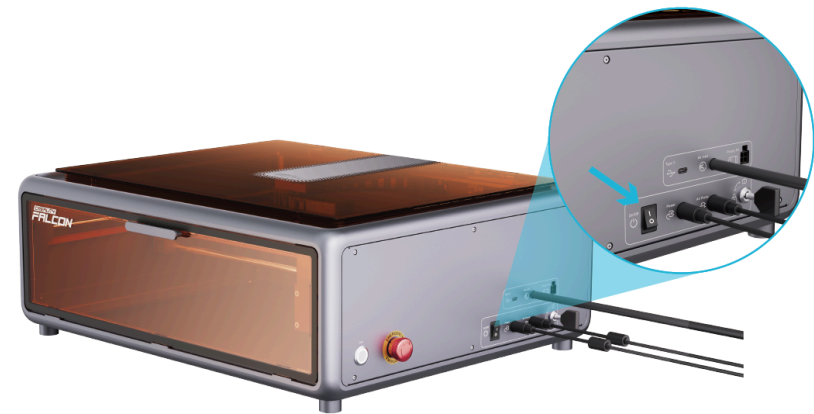

IV. Product Structure

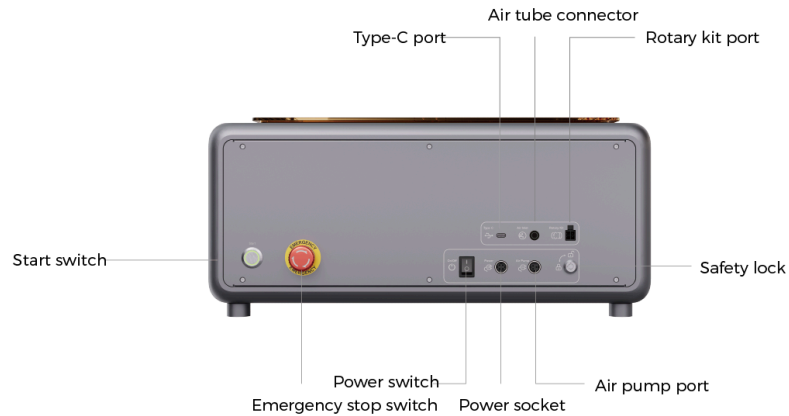

Safety Lock	One of the three safety switches.
Emergency Stop Switch	One of the three safety switches -- for emergency power cut-off.
Power Switch	One of the three safety switches -- for daily operation.
Type-C Port	Connects the computer and device.
Power Port	Connects to power supply for electricity.
Start	After placing the material and adjusting the focus, press Start once to enter frame preview, then press a second time to begin.
Air Pump Port	Connects the air pump to the device for power supply.
Air Tube Connection	Connects the air pump to the device for air flow transmission.
Rotary Kit Port	Connects the rotary kit to the device for operation.

⚠ Indicator Light Status

1. Light off: The machine is powered off or has an abnormal power-on. Please check the triple safety switch.
2. Breathing light effect (gradual brightening and dimming): The machine is in standby mode. Press the micro switch to enter preview mode or engraving mode.
3. Light flashing: The machine is in upgrade mode or abnormal mode. The buzzer emits rapid beeps. Wait for the upgrade to complete or the abnormality to clear, then it will automatically enter standby mode.
4. Light constantly on: The machine is in preview mode or engraving mode. At this time, the laser head is emitting light. Extra caution is required for safety.

V. Product Specifications

Product Name	Crealty Falcon A1 Laser Engraver	Engraving Area	381mm*305mm
Optical Power	10W	Laser Source	Semiconductor laser
Product Dimensions	567*468*196mm	Laser Wavelength	445±15nm
Net Weight	15.55KG	Safety Class	Class 1 (FDA)
Input Voltage	100-240V- 50-60Hz	Laser Engraving Software	Falcon Design Space、LightBurn、LaserGRBL
Output Voltage	DC 24.0V 5.0A	Operating System	Windows/MacOS
Operating Temperature	5°C-35°C	Supported File Formats	jpeg, jpg, png, bmp, svg, dxf, etc.
Safety Certifications	FDA, CE, ROHS, FCC, PSE	Supported Materials	Cardboard, wood, bamboo, rubber, leather, fabric, acrylic, plastic, etc.

Compliant Standards: EN60204-1:2018,EN ISO 12100:2010,ENISO 115553-1:2020, EN 60825-1:2014

VI. Laser Module



Power: Indicates power is on.

Laser: Indicates laser is emitting normal beam.

VII. Instructions for Use



1. After placing different materials, it is necessary to use multi-level focusing strips to adjust the height of the laser module.
2. For basic parameter settings of the laser engraver, refer to the file "GRBL Basic Parameter Description" at wiki.creality.com/en/laser-engraver.
3. Firmware upgrade - "<https://www.crealitycloud.cn/en/software-firmware/other?type=16>" To use the latest version of firmware, you can download the real-time updated firmware version here. First, please empty the (self-provided) USB drive to prevent lag during use, then save the newly downloaded BIN file to the root directory of the (self-provided) USB drive.

A. Mainboard firmware upgrade

With the power off, copy the firmware upgrade package to the (self-provided) USB drive, connect the USB drive to the machine using an A to C adapter, and the device will automatically update when powered on. The buzzer will sound continuously during the update process, and when the sound stops, the update is complete.

⚠ Note: Do not disconnect power during the update process

3. Software installation and use

The device can work online through an A to C connection cable (Falcon Design Space/LightBurn/LaserGRBL), or offline through a (self-provided) USB drive (Falcon Design Space/LightBurn). For detailed software tutorials, please refer to wiki.creality.com/en/laser-engraver.

Note: Related product information can be obtained from wiki.creality.com/en/laser-engraver - product manual, assembly instruction video, camera calibration and alignment, parameter recommendation table, software operation tutorial, G-Code, error code description, GRBL basic parameter description, FAQ, etc.

A. Online Operation

Connect the device to the software in real-time using the Type-A to Type-C cable. Note: For information about real-time operation with the Type-A to Type-C cable, please refer to the corresponding model's documentation at wiki.creality.com/en/laser-engraver. Camera calibration is not mandatory. If there is a significant positioning deviation, it is recommended to recalibrate.

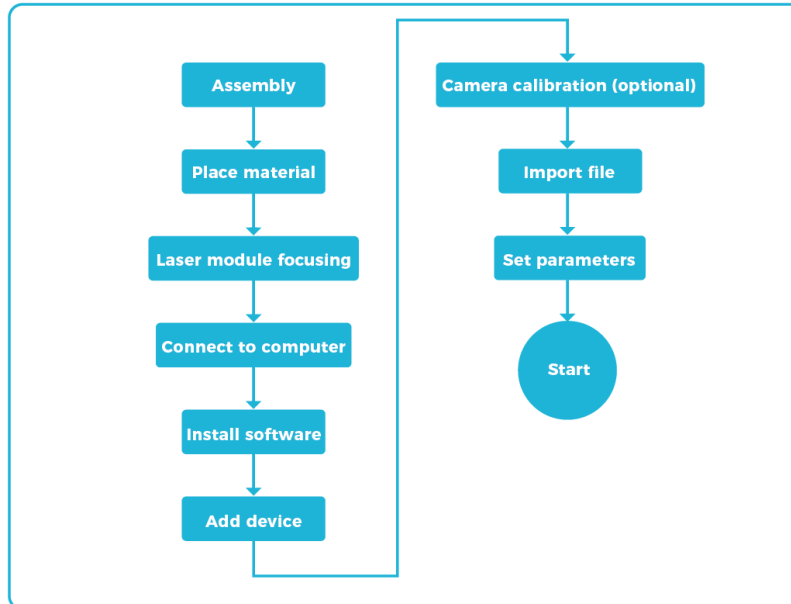

1. Press the "start" button, and the machine will enter preview mode from standby mode. The laser head will emit a weak light and repeatedly move around the maximum X and Y edges of the image to be processed. The indicator light will remain on, allowing you to adjust the material to the appropriate position.
2. In preview mode, press "start" again, and the machine will enter working mode. At this time, the laser head will emit a strong light, the machine will start, and the indicator light will remain on. If you need to pause, press "start", and the indicator light will change to a breathing light effect. Press "start" again to continue. If you need to cancel, press and hold "start" for 3 seconds, after which the machine will reset and enter standby mode, and the indicator light will change to a breathing light effect.
3. After the work is completed, the machine will reset and enter standby mode, and the indicator light will change to a breathing light effect.

B. Offline Operation

Generate engraving or cutting files (G-code) using software (Falcon Design Space/Light-Burn). Save the files to the root directory of a (self-provided) USB drive. Before powering on, connect the (self-provided) USB drive to the device using an A to C adapter. After connecting the power, the device will beep twice. Once the device initializes, it will enter standby mode, and the indicator light will turn on.

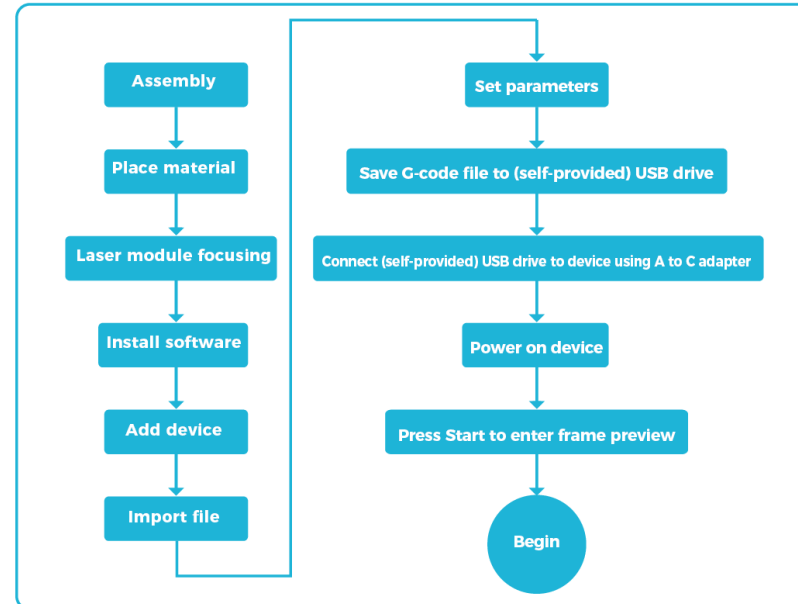

Note:

1. The (self-provided) USB flash drive needs to be in FAT32 format.
2. The (self-provided) USB flash drive only contains one firmware that needs to be updated, and no other redundant files.
3. Do not insert two firmware packages with different versions into the machine for updating at the same time, which will cause a circular update.
4. The USB flash drive temporarily does not support hot plugging. If the machine fails to recognize the (self-provided) USB flash drive, please restart the machine.
5. The device reads the latest engraving file in the first-level directory of the (self-provided) USB flash drive by default. It is recommended to delete other engraving files in the first-level directory.

VIII. Maintenance

After long-term use and dust accumulation, it is recommended to perform overall cleaning and maintenance on the machine monthly. The following areas require special attention:

1. Fan air intake positions.



2. Camera cover.

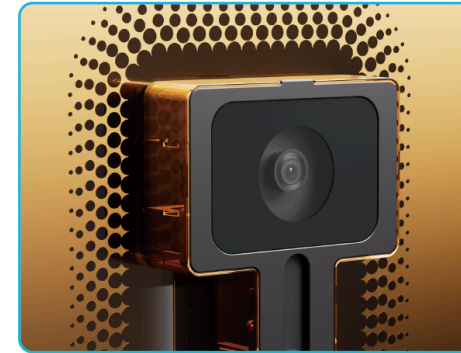

3. Light cover.



4. Motion frame optical shafts, regularly check the cleanliness of the motion frame optical shafts.



5. Laser module output lens, air guide plate, and air intakes on both sides of the fans. The laser module needs to be disassembled for overall maintenance periodically.

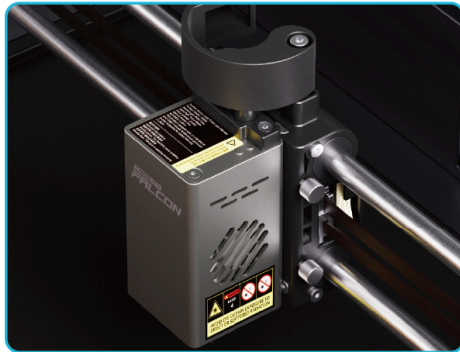

6. The tray needs to be cleaned promptly, do not allow debris to accumulate.

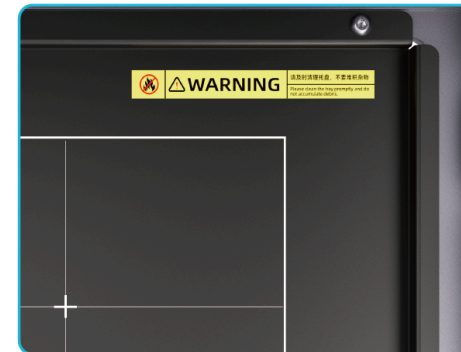

7. After long-term use of the machine, the timing belt needs to be adjusted for tension. It is recommended to check the tension of the timing belt every three months.

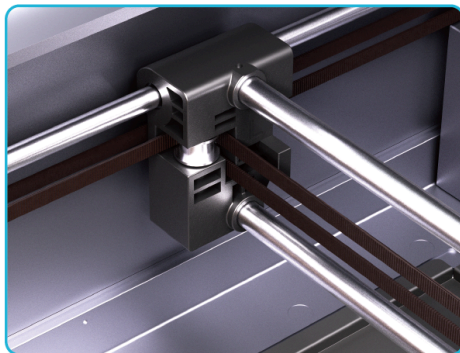

IX. Troubleshooting

Error Code: 01

Machine three-axis angle data abnormal, operation stopped.

Please power off and check if the worktable is shaking, if the machine frame is securely installed, and if all screws are tightened.

Error Code: 02

No G-Code files in the root directory of the (self-provided) USB drive.

Please check if the file extension in the (self-provided) USB drive is ".gcode/.gc/.nc", and ensure the file is stored in the root directory.

Error Code: 14

Main CPU temperature too high.

Please check if the ambient temperature is too high. It is recommended to wait for the host to cool down to a suitable temperature before working.

Error Code: 24

Machine is not in a closed state.

Please close the protective cover and drawer. After closing, press the start button on the device to continue working.

Error Code: 25

Air pump abnormal.

Please contact after-sales service for relevant technical support.



Crealty Falcon Wiki



Official Website

SHENZHEN CREALTY ECOSYSTEM TECHNOLOGY CO., LTD.

Brand Website: www.crealtyfalcon.com

Business Tel: +86 755-8523 4565

Room 1205, JinXiuHongDu Building, Meilong Blvd., Longhua Dist., Shenzhen, China 518131

E-mail: support@crealityfalcon.com

Company Website: www.crealty.com



