

MetroY Ultra Series 3D Scanner

Quick Start Guide

V1.1

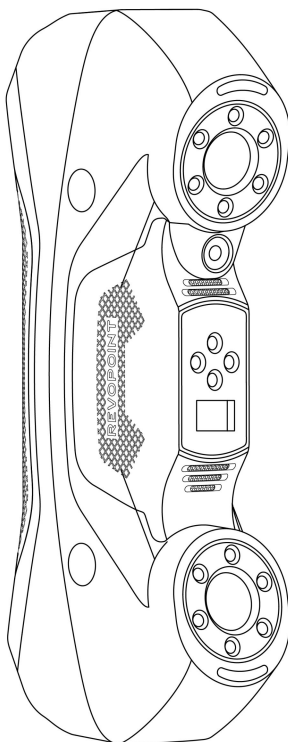

Contents

 What's in the Box	1
 Product Profile	2
 Safety Instructions	3
 System Requirements	3
 Scanner Connection	4
Wired Connection	4
Wireless Connection	4
 Scanning Tips	5
 Scanner Calibration	6
 Software Interface Overview	7
 Ball Plate Measurement	7
IC Warning	8
FCC Warning	8

What's in the Box

1



MetroY Ultra Series
3D Scanner

2

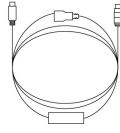

USB Type-C to
Type-C Cable

3

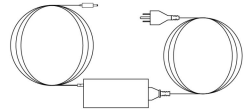

Power Adapter

4



Markers x 500

5



Carrying Case

6

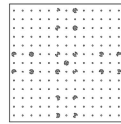

Calibration Board

7



Quick Start Guide
Certificate & Warranty

8

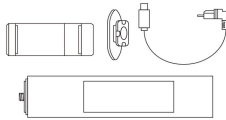

Mobile Kit (4th Gen)

9

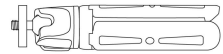

Tripod

10

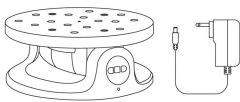

Dual-axis Turntable

11



Sample Bust

12

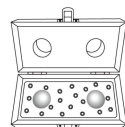

Ball Plate

MetroY Ultra
CMM

*For reference only.

Note: The Power Adapter may vary depending on the country or region.

Product Profile

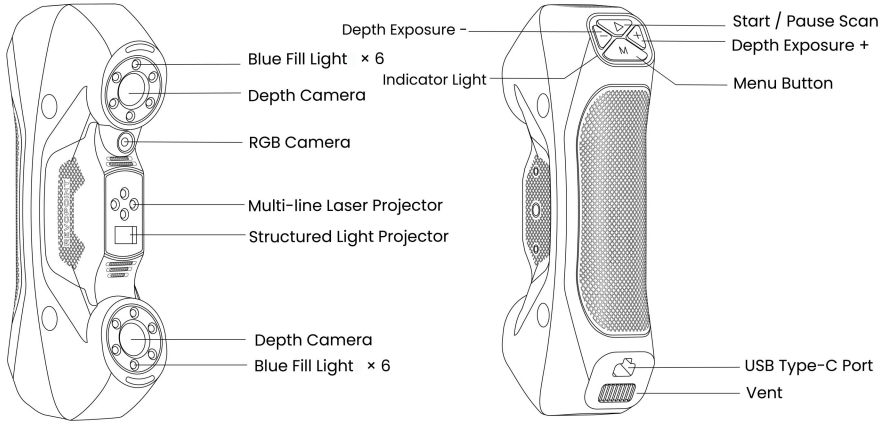

Indicator Light States

Green - Single flash	Power on
Red - Flashing	Powering up
Green - Solid	Powered
Green - Flashing	Operating normally

Button Functions

▶	Start/Pause
+	Increase depth camera exposure
-	Decrease depth camera exposure
M	Depth Camera Exposure/± Key to Switch Line Laser Type /Laser Brightness/± Key to Toggle Full Screen

Safety Instructions

1. Product Laser Specifications

It is classified as a CLASS 2M LASER PRODUCT.



2. Laser Safety

Before use, please wear laser safety goggles and follow the safety instructions below.

- ! Do not stare directly at the 450nm laser beam.
- ! Do not direct the laser beam toward others or yourself.
- ! Do not track the laser beam with the naked eye.
- ! Do not operate without laser safety goggles. Do not substitute regular glasses or sunglasses for laser safety goggles.
- ! Do not observe the laser beam through optical instruments or any other magnifying devices.

3. Maintenance and Operation Safety

- ! Do not remove, disassemble, or modify any part of the product. Any modifications to the product may render it non-compliant with safety standards.
- ! Please keep the scanner away from water and other liquids, and avoid dropping or hitting it.
- ! This product's operating environment temperature range is 0°C to 40°C (32°F to 104°F). Please use the product only within this range.
- ! Keep this product out of the reach of children.

System Requirements

Before your first scan, please download the Revo Metro software from Revopoint's website at global.revopoint3d.com. The system requirements are as follows (please refer to the website for the latest information):

Minimum PC Requirements	
<p>Windows</p> <p>System Version: Windows 10/11 (64-bit)</p> <p>RAM: ≥ 32 GB</p> <p>CPU: Intel i7 13th Gen or AMD Ryzen 7 5800</p> <p>GPU: NVIDIA GeForce RTX 3060 (8 GB)</p>	<p>macOS</p> <p>System Version: macOS 11.0 or better</p> <p>RAM: ≥ 16 GB</p> <p>CPU: M2 Pro</p>

Recommended PC Requirements

Windows

System Version: Windows 10/11 (64-bit)
RAM: ≥ 64 GB
CPU: Intel i9 12th Gen or better
GPU: NVIDIA RTX 4060 (8 GB) or better

macOS

System Version: macOS 11.0 or better
RAM: ≥ 24 GB
CPU: M4 Pro or better

Note: If you're unsure about the CPU configuration, please ensure that the CPU has cores ≥ 8, threads ≥ 16, and a base frequency ≥ 2.4GHz. Please ensure the USB port on your PC is USB 3.0 or above. Only in Laser Line Scanning modes, a dedicated graphics card is required for acceleration. AMD and MAC GPUs do not currently support acceleration.

Scanner Connection

Wired Connection

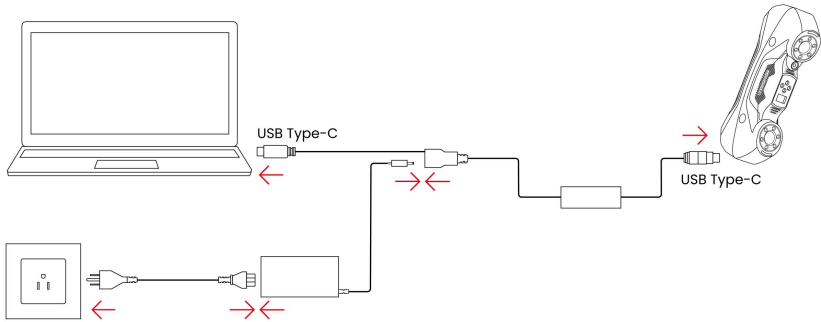

As shown in the above diagram, power the scanner and connect it to the PC's USB 3.0 Type-C port.

Note: The two ends of the USB cable must not be used interchangeably. Follow the labels on the connectors to ensure correct connection between the scanner and the computer. If the connection fails or the frame rate drops below 10 fps, disconnect from the PC while leaving the power on, then reconnect the connector.

Wireless Connection

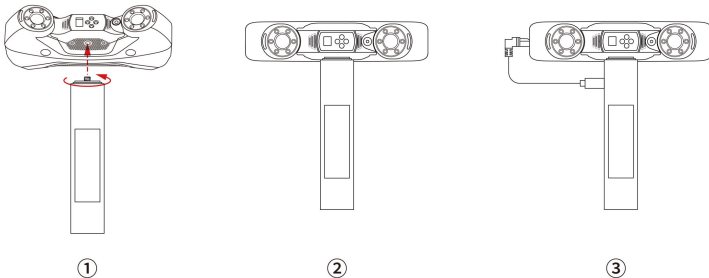

1. Follow steps ① and ② to assemble the scanner and the battery grip.
2. According to step ③, connect the battery grip to the scanner using the power cable from the Mobile Kit for power supply.
3. Find and connect to the Wi-Fi network “METROY Ultra-REVO-XXXXXXX” (no password required) on your PC. Open Revo Metro, wait for the scanner to connect, then start scanning.

MetroY Ultra also supports wireless casting to a phone via Revo Mirror:

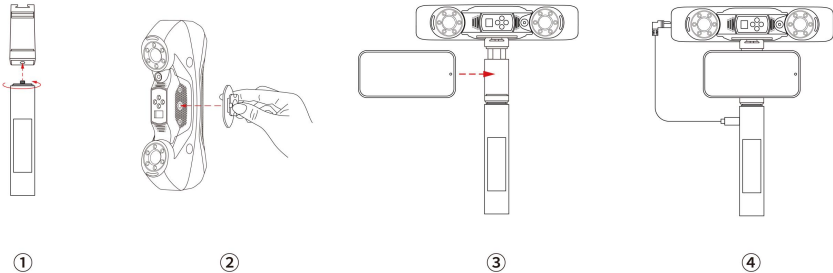

1. Following steps ①, ②, and ③, mount the Mobile Kit (phone holder, battery grip, quick-release plate) onto the scanner.
2. According to step ④, connect the battery grip to the scanner using the power cable from the Mobile Kit for power supply.
3. Download the Revo Mirror software for both your PC and phone from the Support - Download section on Revopoint’s website.
4. After connecting both PC and phone to the “METROY Ultra-REVO-XXXXXXX” Wi-Fi, open Revo Metro on the computer, wait for the scanner to connect and enter the scanning page, then click the casting button.
5. Tap the detected device to be mirrored in the mobile Revo Mirror app.
6. Follow the prompt on the PC to enter the PIN code to complete the initial pairing. Then, click “Enter Screen Mirror Mode” to control the scanning process.

Note: Mobile Kit can be purchased from Revopoint’s online stores.

Scanning Tips

- ① Operate the scanner at room temperature around 20°C (68°F). Warm up the device for 10 minutes before calibration and use of the laser line mode to achieve optimal accuracy.
- ② Scan in a clean indoor environment and ensure that there are no other objects within the scanner’s field of view.

- ③ When using Marker Scan, place markers irregularly on the object, ensuring at least 5 markers can be detected in a frame. **For best accuracy, attach markers to flat surfaces and avoid soft pads or cloths.**

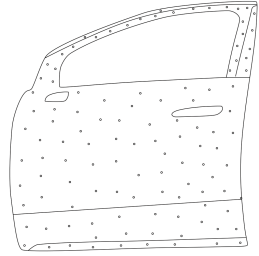

④ **Instructions for Using Scanning Spray**

- For transparent or highly reflective objects (e.g., glass, stainless steel, electroplated surfaces), both line laser and structured light scanning require scanning spray.
- For dark reflective or metallic reflective surfaces (e.g., black paint, machined aluminum alloy), line laser scanning can be performed without spray, but Full-field scanning and Auto Turntable scanning require scanning spray.

| Scanner Calibration

Recalibrate the scanner via Revo Metro's home page using the Calibration program to maintain accuracy. The scanner was professionally calibrated at the factory. **Before scanning, check accuracy through the calibration program and recalibrate as instructed if needed.** Ensure the computer is plugged in during calibration. You can calibrate the scanner as follows:

- ① Download the latest version of Revo Metro from the Support - Download section on Revopoint's website at global.revopoint3d.com and open it.
- ② Power the scanner and connect it to a USB 3.0 port on a PC using the provided USB Type-C to Type-C Cable and power adapter.
- ③ When the software shows Scanner Connected, click [Scanner Calibration] on the bottom left of Revo Metro's Home page to start calibration.
- ④ Complete the accuracy check and calibration following the on-screen instructions.

Software Interface Overview

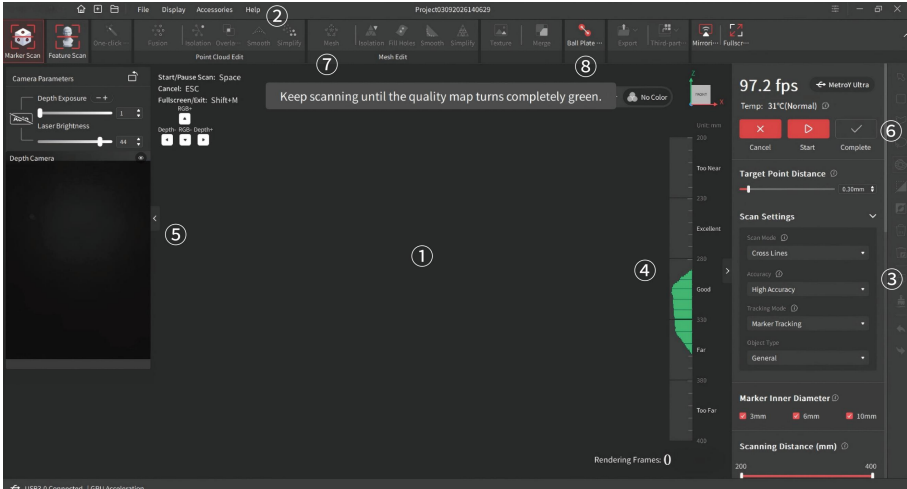

※ Please refer to the actual interface in Revo Metro.

- ① Central Preview Window
- ② Menu Bar
- ③ Scan Settings
- ④ Scanning Distance Indicator Bar
- ⑤ Depth Camera Window
- ⑥ Scanning Controls Window
- ⑦ Model Editing Toolbar
- ⑧ Ball Plate Measurement

Note: To learn more about scanning modes and software usage, please refer to the online user manual on the software learning page.

Ball Plate Measurement

MetroY Ultra supports accuracy verification with the Ball Plate in Revo Metro.

- ① Click “Ball Plate Measurement” at the top of the scan page to start the scanning workflow.
- ② Follow the on-screen instructions to perform global marker scan first, making sure all markers on the plate are fully captured.
- ③ Once the markers are collected, click “Cloud Scan” and scan both the spheres and the plate as completely as possible.
- ④ Click “Complete” to end the scan. The system will automatically process the data and generate an accuracy analysis. Enter the ball plate reference value to view deviation results.

Note: For first-time use, it is recommended to perform calibration and ball plate measurement first, and begin scanning only after the accuracy has been verified.

IC Warning

This device complies with Industry Canada's license-exempt RSS standard(s). Operation is subject to the following two conditions:

- (1) this device may not cause interference, and
- (2) this device must accept any interference, including interference that may cause undesired operation of the device.

This Class B digital apparatus complies with Canadian ICES-003.

IC RF Statement:

When using the product, maintain a distance of 20 cm from the body to ensure compliance with RF exposure requirements.

FCC Warning

This device complies with part 15 of the FCC Rules. Operation is subject to the following two conditions:

- (1) This device may not cause harmful interference, and
- (2) this device must accept any interference received, including interference that may cause undesired operation.

Any Changes or modifications not expressly approved by the party responsible for compliance could void the user's authority to operate the equipment.

Note: This equipment has been tested and found to comply with the limits for a Class B digital device, pursuant to part 15 of the FCC Rules. These limits are designed to provide reasonable protection against harmful interference in a residential installation. This equipment generates uses and can radiate radio frequency energy and, if not installed and used in accordance with the instructions, may cause harmful interference to radio communications. However, there is no guarantee that interference will not occur in a particular installation. If this equipment does cause harmful interference to radio or television reception, which can be determined by turning the equipment off and on, the user is encouraged to try to correct the interference by one or more of the following measures:

- Reorient or relocate the receiving antenna.
- Increase the separation between the equipment and receiver.
- Connect the equipment to an outlet on a circuit different from that to which the receiver is connected.
- Consult the dealer or an experienced radio/TV technician for help.

This equipment complies with FCC radiation exposure limits set forth for an uncontrolled environment.

This equipment should be installed and operated with a minimum distance of 20cm between the radiator & your body.

User Manual



Tutorial Videos



Follow US



Contact US

