

CR Scan Otter

User Manual

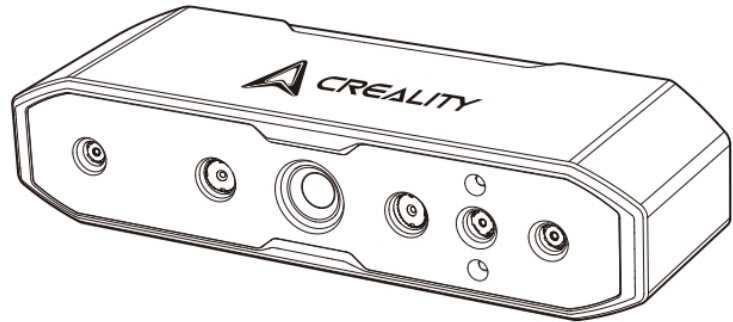

CR-SCAN OTTER

3D SCANNER

SMALL TO LARGE. SCAN IT, MAKE IT

Product Manual V1.0

01. Product Introduction

CR-Scan Otter is a high-precision, handheld, all-in-one 3D scanner compatible with scanning small, medium, and large objects. With a maximum accuracy of 0.02mm. From small screws to human bodies and large automotive components (10~2,000 mm³), it can effortlessly scan objects of various sizes. The ability to adapt to objects of various sizes is achieved by its innovative four-eye stereoscopic vision design. This includes a set of large focal length binoculars and a set of short focus length binoculars. The former is used to capture the details of small and medium objects at close range; the latter has a larger FOV and is used to scan relatively large objects, to ensure stable tracking with minimal loss.

This scanner is equipped with a depth computing specialized chip independently developed by us, which ensures smooth scanning with a maximum frame rate of up to 20fps. Using unique single-frame 3D imaging technology, it has excellent anti-shake performance. Advanced DOE structured light projection technology enables 3D scanning even outdoors ($\leq 30,000$ lux). With professional-grade texture supplemental light, it can smoothly complete full-color scans even in low-light environments, and give objects exquisite and realistic textures.

The all-metal body provides excellent heat dissipation, with a fanless design ensuring noise-free operation. Equipped with touch buttons, interactive indicator lights, and audible buttons, it makes operation more convenient and effortless.

⚠️ Since the 3D scanner is a high-precision device, please handle it with care and store it properly. Avoid collisions or drops to prevent a decrease in accuracy or damage.

02. Product Specifications

Accuracy	Up to 0.02mm @ 60mm[1]	IMU	YES	Operating humidity	0-90% RH
3D resolution	0.05-2mm	Color supplemental light	2 white LEDs	Input power	5V \leftrightarrow 3A
Scanning Frame rate	Up to 20fps	Marker recognition enhancement	8 infrared LEDs	Data interface	USB-C/USB3.0/USB2.0
Min. scan volume	10mm x 10mm x 10mm	Laser safety	Class I (eye safe))	Device dimensions	165mmx37mmx59mm
Single capture range	Max. 1350x840mm@1000mm	System support	Windows/macOS(*Wireless scanning accessories are required for iPhone iOS/Android)	Device weight	380g
Technology	Infrared structured light	Wireless scanning	Supported in conjunction with future wireless scanning accessories	Buttons	Touch
Working distance	110mm-1000mm	Operating temperature	-10°C to 40°C	3D imaging camera resolution	1280x800
Color mapping	YES			Audible prompt	Yes
Alignment modes	Geometry/marker/texture			Calibration board	Yes
Output format	OBJ/STL/PLY				

[1] Accuracy is evaluated in laboratory conditions and actual results may be affected by operating environments such as temperature, vibration, and other factors.

03. Product Information

2.1 Equipment overview

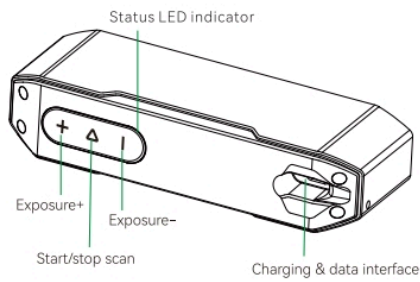
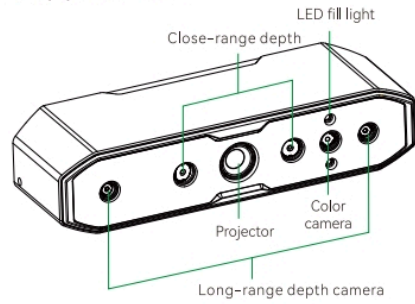

2

2.2 Button instructions

Button	Scanner response	Audible response	LED indicator response
> Button	Short press once to start scanning; short press again to pause scanning; long press ≥ 3 seconds to end scanning.	Beep once	The middle LED indicator flashes once
+ button	Increase IR camera exposure time by one level	Beep once	The left side LED indicator flashes once
- button	Decrease IR camera exposure time by one level	Beep once	The right side LED indicator flashes once

*Note: Audible response can be set to silent mode in the Creality Scan software.

2.3 LED indicator strip

LED indicator strip color	Status or meaning	Reference color
Green	The device is operating normally or the scanning distance is moderate	
Red and flashing	The device is in an abnormal state	
Yellow and flashing	The device is in an upgrading state	
Orange-red	The scanning distance is too close	
Orange	The scanning distance is close	
Light blue	The scanning distance is far	
Dark blue	The scanning distance is too far	

*Note: When the distance LED indicator starts flashing during scanning, it indicates that scanning tracking is lost. The scanner needs to return to the previously scanned area to restore scanning stitching relationships.

04. Packing List



CR-Scan Otter 3D Scanner



USB 3.0 data cable (USB-C/USB-A, 2m)



USB 2.0 power cable (USB-C/USB-A, 1.5m)

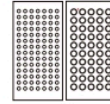

Reflective markers (Diameter: 6mm * 2, Diameter: 3mm * 2)

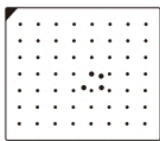

High-precision calibration board



USB-C adapters * 2



Scanning test object (OWL)



Lanyard



Scanning pad (requires random application of 3mm markers for use)



Cleaning cloth



Quick start guide, certification & warranty card



Portable case

3

05. Device Connection

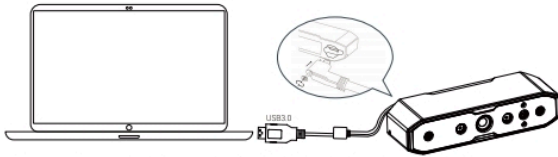

Method 1: Connect to the computer's USB 3.0 port using the USB 3.0 data cable (USB 3.0 and above ports are generally blue or red)

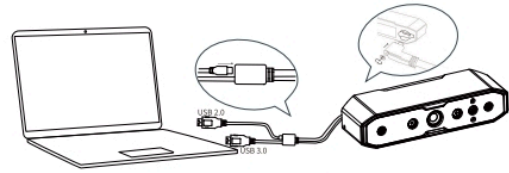

Method 2: If the computer only has USB 2.0 ports or insufficient power supply from the USB 3.0 port, use the USB 2.0 power cable for auxiliary power. Connect the USB 2.0 cable to the middle port of the USB 3.0 (as shown in the figure), and the other side of the port can be simultaneously connected to another port on the computer or used with a 5V charger to provide auxiliary power to the scanner.

06. CealityScan Software System Operation

6.1 Software system requirements of Ceality Scan



System requirements: Windows 10/11 (64 bit)
 Configuration requirements
 Recommended configuration: CPU i7-Gen7 and above, Nvidia or AMD graphics card, 16GB RAM or higher;
 Minimum configuration: CPU i5-Gen8 and above, 8GB RAM or higher.



Recommended configuration
 macOS: 11.7.7 and above (Big Sur/Monterey/Ventura)
 CPU: Apple M1/M2/M3 series processors; RAM: 16GB or higher;
 Minimum configuration
 macOS: 10.15.7 and above (Catalina/Big Sur/Monterey/Ventura)
 CPU: Intel processor (i5-Gen8 CPU and above); RAM: 8GB or higher.

4

6.2 Ceality Scan software download and installation

Download link for Ceality 3D Scanner Software: wiki.creality.com
 Go to wiki.creality.com, click on [Software] -> [Ceality Scan] to download the Ceality scanning software and install it. Please ensure that the software version is 3.1.6 or higher to ensure the normal operation of the scanner.

Note: After installing the Ceality Scan software on MAC, please authorize the software to read and write files to optimize point clouds and generate models when using the software.

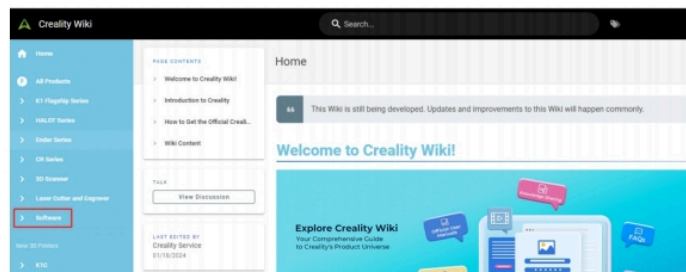

07. First Scan

1. Connect the scanner with reference to "05 Device Connection".

2. Note: During handheld scanning, to prevent the scanner from slipping out of hand and causing damage, you can attach one end of the provided lanyard to the scanner as shown in the figure, and loop the other end around your wrist.



3. Open the installed Ceality Scan software and perform the first scan experience with the included test object (OWL). Refer to the right table for scan parameters.

Object	<input checked="" type="checkbox"/> Normal	<input type="checkbox"/> Face	<input type="checkbox"/> Body
Size	<input type="checkbox"/> Large	<input type="checkbox"/> Middle	<input checked="" type="checkbox"/> Small
Feature	<input checked="" type="checkbox"/> Geometry	<input type="checkbox"/> Texture	
Accuracy	<input type="checkbox"/> Fast	<input checked="" type="checkbox"/> Hi-Quality	
Color Mapping	<input checked="" type="checkbox"/> Color	<input type="checkbox"/> No Color	
Turntable	<input type="checkbox"/> Yes	<input checked="" type="checkbox"/> No	

5

4. Ensure the scanning environment is clean and spacious. Adjust the scanner to an appropriate distance from the test object: when the scanner LED indicator is green or when the distance indicator on the left side of the software interface is optimal (green), it indicates the optimal scanning distance.



5. Press \triangleright button on the scanner briefly, or click "Start Scan" on the software interface to initiate scanning. Move the scanner slowly and try to keep the test object in the center of the preview window above. Continue scanning until the model turns green.



6. When part of the scan is complete, you can click \square to pause, change the model orientation, and then click \square to resume scanning. After completing the scan, long-press \square on the scanner for more than 3 seconds, or click "Stop Scan" on the software interface to finish the scan.



7. Data processing: Perform data processing in the Creality Scan software (one-click/step-by-step processing) to obtain a complete 3D model (recommended dot pitch setting: 0.1mm).

Note: For tutorials on scanning different objects and data processing, please scan the QR code on the right.



6

08. FAQs

- How to achieve better model details?
 - ① Adjust the exposure time of the IR camera during scanning to ensure moderate exposure. Overexposure is shown as red, while underexposure is shown as blue.
 - ② Try to maintain the optimal scanning distance. Generally, the closer the scanner is to the object without losing tracking, the better the details.
 - ③ During point cloud optimization, use a smaller point distance: For example, when the object size is small, the point distance can be set to 0.1mm.
 - ④ When meshing, ensure that the number of model faces is sufficiently large.For more scanning tips, please visit: <https://wiki.creality.com/3d-scanner>
- How to scan the bottom of an object?
 - ① Creality Scan provides a multi-project merging feature, allowing you to obtain the complete model of an object through different orientation and merge together.
 - ② Scan the visible part of the object first to obtain a partial model, pause the scan, then change the object's orientation, and continue tracking the previously scanned part to get the complete model.
- When do you need to use a scanning pad?

When scanning smaller objects (such as wireless earbuds, medals, etc.), you can randomly place 3mm diameter marker points on the scanning pad and select the marker point mode for scanning.
- When do you need to use the USB 2.0 power cable?

When the computer cannot connect to the scanner due to an insufficient power supply, you can use this charging cable to connect an external charger to power the scanner. When the scanner is connected to a computer's USB 3.0 port and has sufficient power supply without using a docking station, you generally do not need to connect an additional power cable.
- When do you need to use the marker point mode or texture mode?

When the geometric features on the surface of the object are not prominent, you can apply the reflective marker points included in the package to the object and use the marker point mode for scanning. When the surface of the object has rich textures, you can directly use the texture mode for scanning.
- When is calibration necessary?

Calibration is necessary when the device has not been used for a long time (such as 3 months), or when the device has been accidentally bumped.

Note: The 3D scanner is a high-precision device, please handle it with care, and avoid collisions or drops to prevent damage or degradation to accuracy.
- Can calibration cards be swapped for each other?

Each calibration card is unique and corresponds to each scanner. They cannot be swapped. When using a calibration board for the first time, it needs to be scanned once to bind to the scanner using the QR code on the back. Otherwise, it may affect calibration accuracy.
- What should be noted when storing calibration boards?

After each use, please carefully store the calibration card to its original box for proper storage. Avoid contamination, scratching, or heavy pressure on the calibration card to prevent loss or damage.
- How to perform calibration?

Connect the scanner to the computer, open the Creality Scan software, go to the [Device] interface, click on [Calibration], and perform calibration by following the animated instructions.

7

09. Troubleshooting

- The Win system computer cannot connect to the scanner;
If using a desktop computer, it is recommended to connect to the USB 3.0 port on the back of the main unit (USB 3.0 and above ports are usually blue or red);
Confirm that the system used is Windows 10/11 64-bit;
The full installation paths for the scanner software Creality Scan must be in English.
- What to do if the preview is not visible in the application on the Win system;
Use the provided charging cable to connect to a charger to ensure a normal power supply for the scanner;
Open the Windows Device Manager and check if there is a "CR-Scan Otter..." related camera under "Cameras";
Open Windows Settings-Privacy-Camera, confirm whether the system camera permission is turned on, and ensure that desktop applications have permission to access the camera.
- What to do if the preview is not visible in the application on the Mac system?
Use the provided charging cable to connect to a charger to ensure a normal power supply for the scanner;
Update the scanner to the latest firmware;
Use a standalone adapter (the scanner comes with a USB-A to USB-C adapter), and avoid using multifunctional USB adapters whenever possible;
Install Creality Scan directly in the computer's Applications directory. Avoid installation within subdirectories of the Applications directory.
- How to deal with USB 3.0 interface being recognized as USB 2.0 in the Windows system?
You can try quickly reinserting the USB cable or first connect the USB 3.0 interface and then connect the scanner's USB-C interface.
For further questions, please refer to the scanner wiki link:
<https://wiki.creality.com/en/3d-scanner/cr-scan-otter>

Facebook Community
Discussion, sharing, and
troubleshooting



Tutorials
Master the art
of scanning!



SHENZHEN CREALITY 3D TECHNOLOGY CO.,LTD.

Official Website: www.creality.com

Business Tel: +86 755-8523 4565 E-mail: cs@creality.com

Company Address: 18th Floor, JinXiuHongDu Building, Meilong Road,
Xinniu Community, Minzhi Street, Longhua District, Shenzhen City, China.

